

INSTRUCTIONS

Series 1502

DIFFERENTIAL PRESSURE INSTRUMENTS



Orange Research Inc.

140 Cascade Boulevard, Milford, Connecticut 06460
203 877-5657 800 989-5657 Fax: 203 783-9546
www.orangeresearch.com

Your new Orange Research Differential Pressure Instrument is a rugged instrument featuring simplicity of design to provide dependable and efficient service. Because it is an instrument it should be handled with care. Read all instructions carefully before attempting to install the instrument.

CAUTION: Do not exceed nameplate maximum operating pressure. Use only fluids compatible with wetted parts.

HOW IT WORKS

The instrument operates on the difference between two pressures (delta-P). The sensing element is a spring biased diaphragm which moves linearly in proportion to the difference between two basic pressures. A magnet on the HI pressure side of the piston assembly moves with the diaphragm and rotates a follower magnet located adjacent to the pressure cavity. The gauge pointer is located at the end of the rotary magnet shaft and rotates with the magnet to provide gauge readings proportional to differential pressure variations. There are no mechanical seals between the pressure side of the instrument and the gauge mechanism side. This is accomplished by coupling the forces between two adjacent magnets through a solid wall.

Note: This instrument will provide $\pm 2\%$ accuracy full scale.

Caution: Do not install instrument backwards

The rolling diaphragm is likely to be damaged or ruined if pressure source is applied to the LO side first. Always apply pressure to the HI side first and then the LO side.

It is recommended that the instrument be located above the pressure source to allow drainage of the unit. The height and size of piping can be based upon the .250 cu. In. max. displacement of the pressure chamber.

IMPORTANT: Because of the magnetic movement, this instrument should never be mounted in direct contact with a steel surface. Otherwise a calibration shift will occur. Mount the instrument so that the pressure body is at least 1" away from metal surfaces with non-magnetic spacers or an aluminum-mounting bracket. Flush panel mounted instruments will not be affected by contact with aluminum panels. However, 2" and 2½" gauges flush mounted in a steel panel may require resetting of the pointer at zero. (this should be done at time of manufacture but can be reset in the field with a small loss of accuracy.)

MAINTENANCE

Other than replacing broken lens there is only one area where this instrument may need attention. Erratic pointer or switch action may indicate that cleaning is required. For cleaning:

1. Remove the unit from service.
2. Remove end cap with a 1" spanner wrench.
3. Remove the range spring and the spacers at the bottom of the spring pocket. **BE CAREFUL NOT TO LOSE STACKING SPACERS.**
4. Remove the four ¼-20 socket head screws and separate the body parts. Remove the diaphragm assembly.
5. Separate diaphragm assembly by removing screw **A** (figure 1) **Note:** do not remove screw **B** because it is sealed in place with epoxy resin.
6. Clean parts in a solvent solution after removing the "o"-ring seals since some solvents will attack the seal material.

7. It is good practice to replace the "o"-ring seals and diaphragm while the instrument is dismantled.

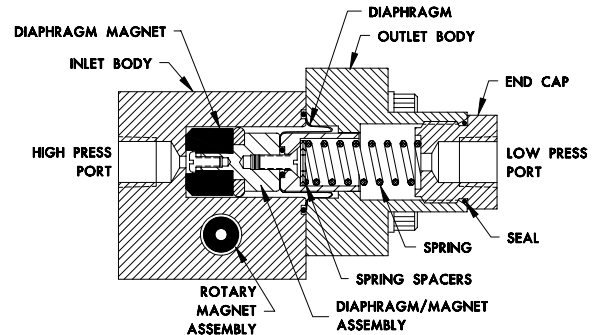

To reassemble:

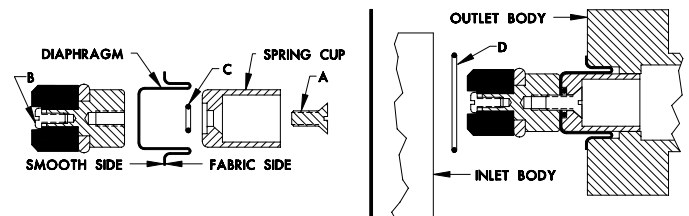

Figure 1

Figure 2

1. Place new diaphragm in position (Figure 1). Note: smooth side of diaphragm must face out. If fabric side is showing, turn diaphragm inside out so that the smooth side shows.
2. Place new "o"-ring **C** in position (Figure 1) and reassemble parts with screw **A**
3. Carefully fold diaphragm back on itself (to establish its working curl) until the diaphragm flange is level with the diaphragm head. Insert the diaphragm assembly into the outlet body (Figure 2).
4. Reassemble the outlet body to the inlet body with four ¼-20 socket head screws (figure 2). **NOTE:** make certain new "o"-ring **D** is between body parts.
5. While holding the instrument with the low pressure side up, insert the spacers and range spring in the spring cup.
6. Assemble new "o"-ring on low pressure end cap and reassemble end cap outlet body. Tighten the end cap and the instrument is now ready for service.

LENS REPLACEMENT: To replace a broken lens, check to see if the lens is held on by a bezel or a snap-ring. To remove a bezel, which is a pressed on cover, either twist off by hand (watch out for the broken glass) or pry off with a screwdriver. To remove a snap-ring, pry out the ring with a small screwdriver. Remove all glass chips, insert new lens and re-insert the bezel or snap. With snap-rings, locate the ring joint at the bottom of the gauge.

POINTER REPLACEMENT: (Probably damaged when lens was broken). Remove bezel or snap-ring as previously described and clean out glass chips. Remove old pointer with pointer puller or two small screwdrivers opposite each other under pointer hub. Pry off evenly being careful not to bend the pointer shaft. Install new pointer dead on zero. Re-install lens, as described under lens replacement.

SWITCH ADJUSTMENT

SWITCH UNITS: On switch and indicating switch models, reed switches are located adjacent to the pressure chamber and are actuated when the diaphragm magnet field interacts at a preset point with the reed switch armature. Reed switch set points are adjustable.

Reed switch set points are field adjustable. On Indicating Switches, the reed switches can be adjusted over the top 80% of the gauge range. On Switch models the reed switches can be adjusted over the range shown on the nameplates.

To change the reed switch setting, loosen the screw on the switch bracket and slide the reed switch. To increase the set point move the reed switch towards the LO port; to decrease the set point move the reed switch toward the HI port. Tighten the reed switch bracket screw and check the new actuation point. Repeat as required until desired setting has been reached.



SWITCH WIRE COLOR

- A SPST white and white
- B SPST green(N/C); blue(common)
- C SPDT green(N/C); red(N/O); blue(common)

REPLACEMENT PARTS

GAUGE DIA.	GLASS LENS	PLASTIC LENS	POINTER	SST BEZEL (press-fit)
2"	GG1-1	GG2-1	AF15-1	M1-5
2 1/2"	GG1-2	GG2-2	AF15-2	M2-5
3 1/2"	GG1-3	GG2-3	AF15-3	M4-5
4 1/2"	GG1-4	GG2-4	AF15-4	M5-5
6"	GG1-5	GG2-5	AF15-5	---

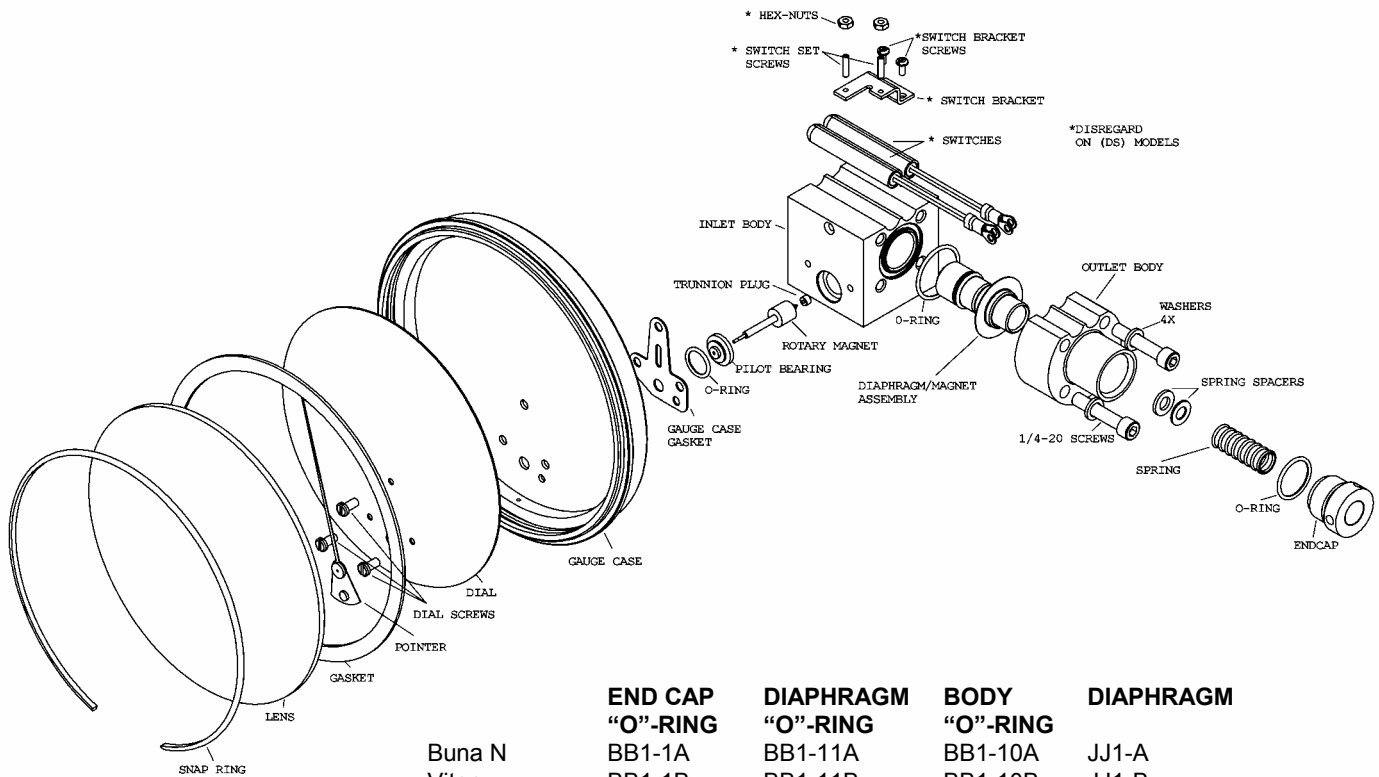

	END CAP "O"-RING	DIAPHRAGM "O"-RING	BODY "O"-RING	DIAPHRAGM
Buna N	BB1-1A	BB1-11A	BB1-10A	JJ1-A
Viton	BB1-1B	BB1-11B	BB1-10B	JJ1-B
Teflon	BB1-1F	BB1-11F	BB1-10F	---
EPDM	BB1-1E	BB1-11E	BB1-10E	JJ1-F
Fluorosilicone	BB1-1C	BB1-11C	BB1-10C	JJ1-C

RECALIBRATION

Recalibration of this instrument is not required. However, if the range spring is damaged or a new dial is required, the instrument must be returned to the factory for the parts and recalibration.

NOTE: When ordering replacement parts, identify instrument SO# or WO# from the nameplate. Identify parts required and quantity.