

INSTRUCTIONS

Series 1835

DIFFERENTIAL PRESSURE INSTRUMENTS



Orange Research Inc.

140 Cascade Boulevard, Milford, Connecticut 06460
203 877-5657 800 989-5657 Fax: 203 783-9546
www.orangeresearch.com

Your new Orange Research Differential Pressure Instrument is a rugged instrument featuring simplicity of design to provide dependable and efficient service. Because it is an instrument it should be handled with care. Read all instructions carefully before attempting to install the instrument.

CAUTION: Do not exceed nameplate maximum operating pressure. Use only fluids compatible with wetted parts.

HOW IT WORKS

The instrument operates on the difference between two pressures (delta-P). The sensing element is a spring biased diaphragm which moves linearly in proportion to the difference between two basic pressures. A magnet on the LO pressure side of the piston assembly moves with the diaphragm and rotates a follower magnet located adjacent to the pressure cavity. The gauge pointer is located at the end of the rotary magnet shaft and rotates with the magnet to provide gauge readings proportional to differential pressure variations. There are no mechanical seals between the pressure side of the instrument and the gauge mechanism side. This is accomplished by coupling the forces between two adjacent magnets through a solid wall.

Note: This instrument will provide $\pm 2\%$ accuracy full scale.

INSTALLATION

Check instrument & identify **HI** and **LO** markings. **HI** identifies the high pressure port; **LO** the low pressure port. If instrument is installed backwards, it will neither operate nor be damaged. Reverse connections if installed backwards. The instrument can be line mounted, bracket mounted or panel mounted depending upon the model purchased.

Under normal conditions Series 1835 instruments are designed for line pressure to 150 psig (for S.S. models & 100 psig for alum. models) and can sustain a continuous forward or reverse overpressure equal to the line pressure.

It's recommended that the instrument be located above the pressure source to allow drainage of the unit. The 1835 model includes vents to purge trapped gasses from the pressure chamber. Turn vent screws c-clockwise to break seal & clockwise to reseal the vents

IMPORTANT: Because of the magnetic movement, this instrument should never be mounted in direct contact with a steel surface. Otherwise a calibration shift will occur. Mount the instrument so that the pressure body is at least 1" away from metal surfaces with non-magnetic spacers or an aluminum-mounting bracket. Flush panel mounted instruments will not be affected by contact with aluminum panels. However, 2" and 2½" gauges flush mounted in a steel panel may require resetting of the pointer at zero. (this should be done at time of manufacture but can be reset in the field with a small loss of accuracy.)

MAINTENANCE

Other than replacing broken lens there is only one area where this instrument may need attention. Erratic pointer or switch action may indicate that cleaning is required. For cleaning:

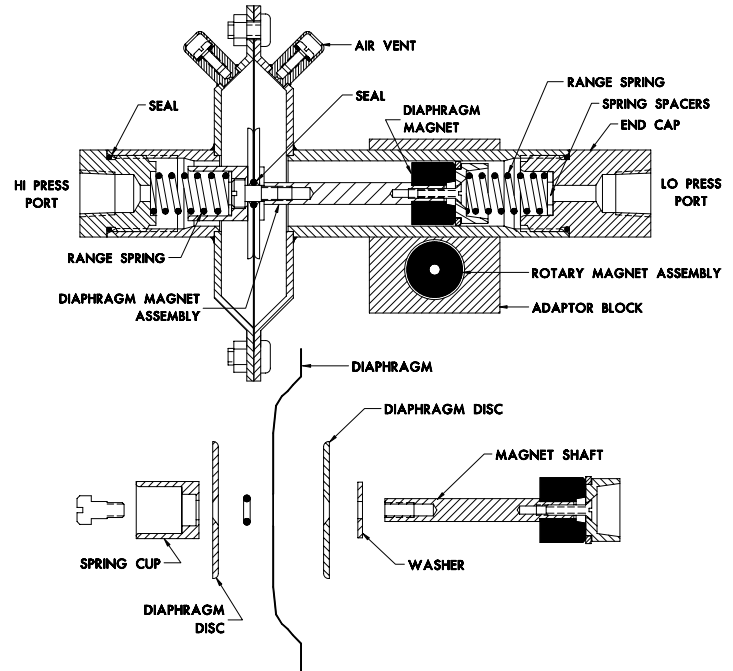

1. Remove the unit from service.
2. Remove the low pressure end cap with a 1" spanner wrench.
3. Remove the range spring and the spacers at the bottom of the spring pocket. **BE CAREFUL NOT TO LOSE STACKING SPACERS, IF ANY.**
4. Remove the 16 #10-32 pan head screws and separate the body parts. Remove the diaphragm assembly.
5. To replace the diaphragm, remove the screw at the top of the diaphragm disc to separate the assembly. **NOTE:** Do not remove the screw in the magnet assembly.
6. Clean parts in a solvent solution after removing the "o"-ring seals since some solvents will attack the seal material.

To reassemble:

1. Place spring cup & diaphragm disc on shoulder screw with the chamfer facing away from screw head. Place new diaphragm over screw with the convolution of the diaphragm oriented as shown. Place the "o"-ring in the center of the diaphragm. Place the second disc over diaphragm so that center chamfer faces the diaphragm "o"-ring.
2. Place the spring cup over the end of the shoulder screw and tighten to finish assembly.
3. Place the diaphragm assembly back into the diaphragm pocket with the magnet end of the assembly at the **LO** pressure side.
4. Reassemble both body parts with the 16 #10-32 pan head screws.
5. Insert the spacers and the range springs into the spring pockets of the end caps. While holding the instrument with the low pressure port down, insert the end cap back into the low pressure side of the body.
6. Tighten the **LO** end cap and the instrument is now ready for service.

SWITCH UNITS: On switch and indicating switch models, reed switches are located adjacent to the pressure chamber and are actuated when the diaphragm magnet field interacts at a preset point with the reed switch armature. Reed switch set points are adjustable.

LENS REPLACEMENT: To replace a broken lens, check to see if the lens is held on by a bezel or a snap-ring. To remove a bezel, which is a pressed on cover, either twist off by hand (watch out for the broken glass) or pry off with a screwdriver. To remove a snap-ring, pry out the ring with a small screwdriver. Remove all glass chips, insert new lens and re-insert the bezel or snap. With snap-rings, locate the ring joint at the bottom of the gauge.

POINTER REPLACEMENT: (Probably damaged when lens was broken). Remove bezel or snap-ring as previously described and clean out glass chips. Remove old pointer with pointer puller or two small screwdrivers opposite each other under pointer hub. Pry off evenly being careful not to bend the pointer shaft. Install new pointer dead on zero. **NOTE:** Gauges with a zero peg must have the pointer set at a reference pressure. (Preferably mid-scale) to offset the preload against the zero peg. Re-install lens, as described under lens replacement.

SWITCH ADJUSTMENT

Reed switch set points are field adjustable points. On Indicating Switches, the reed switches can be adjusted over the top 60% of the gauge range. On Switch models the reed switches can be adjusted over the range shown on the nameplates.

To change the reed switch setting, a source of pressure will be needed with the instrument. Loosen the screw holding the reed switch. To increase the set point, slide the switch tube toward the **LO** port. To decrease the set point, slide the switch tube toward the **HI** port. Repeat as required until new setting is reached. Tighten the screw holding the switch tube in place and recheck the new actuation point.

CAUTION: Do not over tighten the switch holding screw-this is a cone point set screw and digs into the tube with light pressure. (in some cases, it might be necessary to reverse the switch tube end for end to locate the new actuation point-this is normal procedure.)

SWITCH WIRE COLOR

- A SPST white and white
- B SPST green(N/C); blue(common)
- C SPDT green(N/C); red(N/O); blue(common)

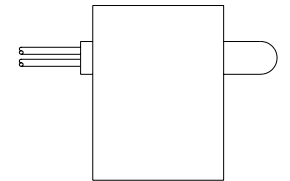

HI PORT **LO PORT**

INC. SETTING →

← DEC. SETTING

REPLACEMENT PARTS

GAUGE DIA.	GLASS LENS	PLASTIC LENS	POINTER	SST BEZEL (press-fit)
2"	GG1-1	GG2-1	AF15-1	M1-5
2 1/2"	GG1-2	GG2-2	AF15-2	M2-5
3 1/2"	GG1-3	GG2-3	AF15-3	M4-5
4 1/2"	GG1-4	GG2-4	AF15-4	M5-5
6"	GG1-5	GG2-5	AF15-5	---

	END CAP "O"-RING	DIAPHRAGM "O"-RING	DIAPHRAGM
Buna N	BB1-1A	BB1-11A	AE7-A
Viton	BB1-1B	BB1-11B	AE7-B
Teflon	BB1-1F	BB1-11F	---
EPDM	BB1-1E	BB1-11E	AE7-F
Fluorosilicone	BB1-1C	BB1-11C	AE7-C

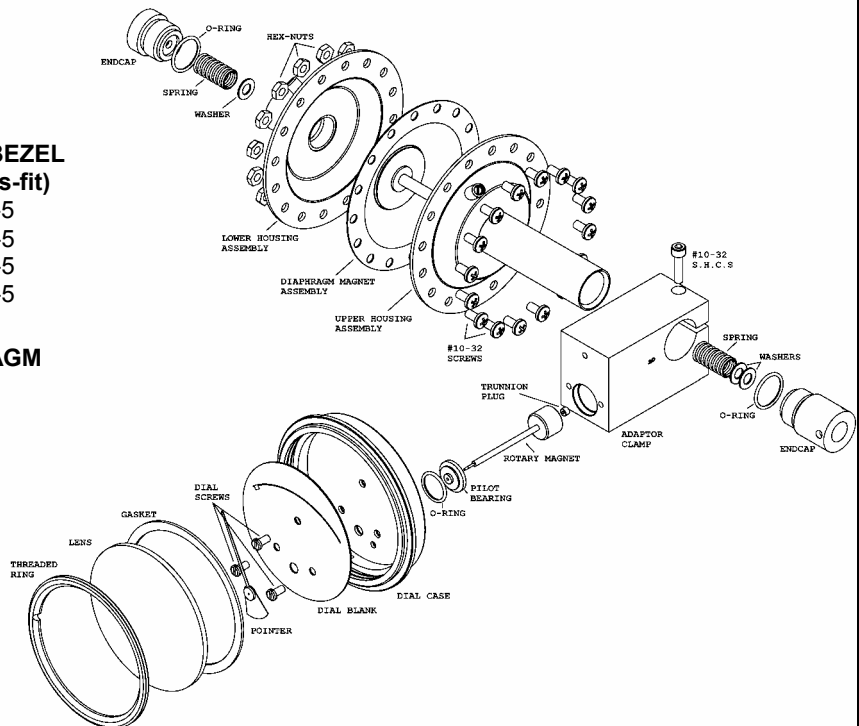

RECALIBRATION

Recalibration of this instrument is not required. However, if the range spring is damaged or a new dial is required, the instrument must be returned to the factory for the parts and recalibration.

NOTE: When ordering replacement parts, identify instrument SO# or WO# from the nameplate. Identify parts required and quantity.